



VITROVEX® – 17" glass spheres

For deep ocean explorations to 12,000 meters



Nautilus Marine Service provides **VITROVEX® 17" glass spheres** in different pressure ratings to full ocean depth along with associated services and accessories. These glass spheres are available either as floatation housings to provide buoyancy for deep ocean research applications or as instrumentation housings to accommodate sensitive electronics for observational activities in deep ocean research.

A **VITROVEX® 17" glass spheres** consists of two mated glass hemispheres that are evacuated and locked into position by a sealant and protective tape.



P/N 790257: VITROVEX Hemisphere OD 432 mm, WS 14 mm
 P/N 790278: VITROVEX Hemisphere OD 432 mm, WS 18 mm
 P/N 790233: VITROVEX Hemisphere OD 432 mm, WS 21 mm

For each instrument sphere a fully assembled vacuum port within a respective drill hole and flat ground is part of the standard package.



P/N 790260, P/N 790262L: Vacuum port



Advantages of VITROVEX® 17" glass spheres

- Immense strength to weight ratio
- Resistant to breaking (low thermal expansion coefficient)
- Remarkable transparency and clarity with smooth, pore-free surface
- Inherently inexpensive
- Corrosion resistant, non-polluting and ecologically acceptable
- Parting plane sealing faces are honed to a precise flatness and finish
- Non-magnetic and electrically non-conductive
- Hemispheres are completely interchangeable and can be replaced individually
- No need to rotate the hemispheres to find matching alignment markers during assembly
- The serial number and a production period are indicated on each hemisphere



■ Models and dimensions

part number floatation spheres	part number instrument spheres	depth rating	glass thickness	protective shell design	p/n	weight in air	weight in water*
NMS-FS-6700-17	NMS-IS-6700-17VP	6,700 m	14 mm	none	-	17.2 kg	-26.0 kg
NMS-FS-6700-17S	NMS-IS-6700-17S	6,700 m	14 mm	smooth	790250	22.2 kg	-26.0 kg
NMS-FS-6700-17RO	NMS-IS-6700-17RO	6,700 m	14 mm	ribbed	790251	22.8 kg	-26.0 kg
NMS-FS-9000-17	NMS-IS-9000-17VP	10,000 m	18 mm	none	-	21.6 kg	-21.0 kg
NMS-FS-9000-17S	NMS-IS-9000-17S	10,000 m	18 mm	smooth	790250	26.6 kg	-21.0 kg
NMS-FS-9000-17RO	NMS-IS-9000-17RO	10,000 m	18 mm	ribbed	790251	27.2 kg	-21.0 kg
NMS-FS-12000-17	NMS-IS-12000-17VP	12,000 m	21 mm	none	-	24.9 kg	-18.0 kg
NMS-FS-12000-17S	NMS-IS-12000-17S	12,000 m	21 mm	smooth	790250	29.9 kg	-18.0 kg
NMS-FS-12000-17RO	NMS-IS-12000-17RO	12,000 m	21 mm	ribbed	790251	30.5 kg	-18.0 kg

* approx. – mainly depending on salinity



Smooth protective shell, P/N 790250



Ribbed protective shell, P/N 790251

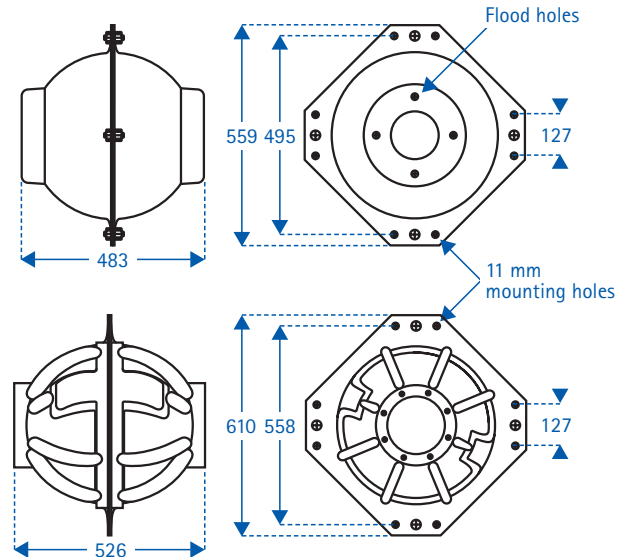

■ Optional features of VITROVEX® 17" glass spheres

instrument spheres

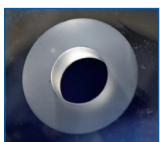

- Additional drill holes with standard (± 0.2 mm) or high accuracy (± 0.1 mm) to accommodate connectors, feedthroughs, and a vacuum port for connection to electronics and batteries inside, or releases, sensors or other packages on the outside



- Adapter plates to avoid bearing stresses for standard connectors



- Optical polishing for high-resolution digital cameras or sensors utilizing light

- Manometer to monitor vacuum

- Paint coating



- Pressure test prior to shipment to guarantee reliability during operation

- Mooring components (swivelling sphere attachments and ropes)

floatation and instrument spheres

- Protective shells are available in smooth or ribbed design and bright orange colour. Protective shells are neutrally buoyant and made of polyethylene



- EDDYROPE (P/N: NMS-FS-OPT1) and KINGROPE (P/N: NMS-FS-OPT3) are specially braided fibre ropes with a diameter of 10 mm and 16 mm and a breaking strength of 5.1 t and 12 t respectively. The ropes are splice terminated with a reinforced thimble and stopper at each end. The stoppers absorb weight and uplift.

- EDDYGRIP (P/N: NMS-FS-OPT2) and KINGGRIP (P/N: NMS-FS-OPT4) are swivelling sphere attachment brackets which are bolted to the protective shell in order to affix the VITROVEX® glass floats onto the EDDYROPE or KINGROPE line segment.

