

CONTROS HydroC™ CH₄

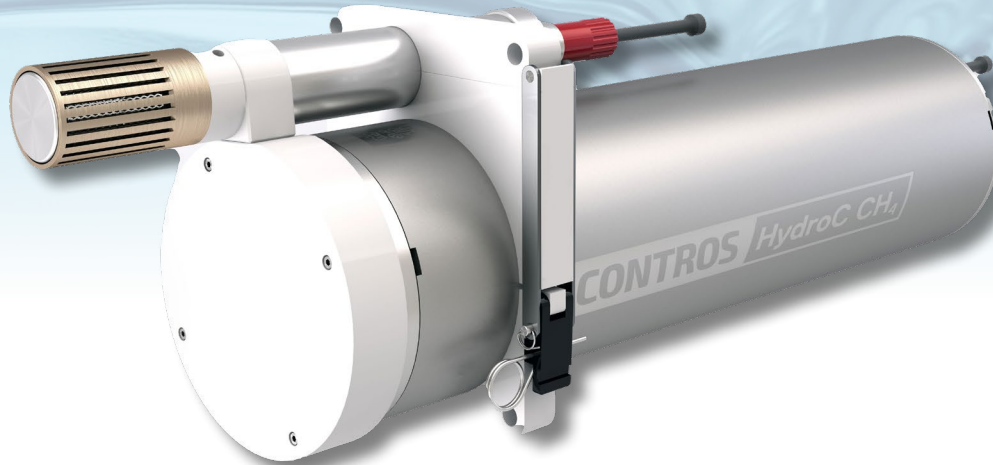

ACCURATE AND STABLE METHANE SENSOR FOR LONG-TERM DEPLOYMENT

Tunable Diode Laser Detectors are accurate with excellent methane molecule selectivity

The CONTROS HydroC™ CH₄ sensor is a unique subsea methane sensor for in-situ and online measurements of CH₄ partial pressure (pCH₄). This versatile sensor is the ideal solution for the monitoring of background CH₄ concentrations, as well as for detecting high peaks of CH₄ in the deep sea environment.

OPERATING PRINCIPLE

Dissolved CH₄ molecules diffuse through the custom-made thin film TOUGH membrane into the internal gas circuit. This leads to a detection chamber where CH₄ concentration is determined by means of Tunable Diode Laser Absorption Spectroscopy (TDLAS). Concentration dependent laser light intensities and additional gas circuit data are converted into an actionable, reliable output signal.

HIGH ACCURACY AND STABILITY

Due to their narrow line-width, Tunable Diode Laser Detectors are accurate with excellent methane molecule selectivity. Further, they feature a large dynamic range covering background partial pressures up to 40 matm. All detectors are subject to individual calibration and an in depth quality check in the -4H-JENA QA lab before they are integrated into our sensors. The quality of the calibration is then verified individually in calibration tanks. The sensor is stable over extended periods as the detector tunes the laser to CH₄ absorbing and non-absorbing wavelengths for each measurement, thus compensating for potential drift influences.

ACCESSORIES

A wide range of available accessories ensures that each of the CONTROS HydroC™ CH₄ sensors can be adapted to meet customers requirements. Underwater pumps and different flow head designs are the most common options and can be delivered quickly. An anti-fouling head is available for conditions with significant bio-fouling challenges and an internal data logger can be specified in conjunction with the sensor's flexible power management features and the CONTROS HydroB® battery packs for long-term, unattended deployments.

SOFTWARE

CONTROS DETECT® includes real-time data visualization, setting of sensor parameters, download of data from internal data logger and sleep mode function.

HARDWARE

- Windows 7 32 Bit or higher
- 200 MB free disk space
- Dual Core CPU with 2GB RAM

OPTIONS

- Available temperature ranges for reduced power consumption:
 - -2°C to +30°C
 - -2°C to +20°C
 - -2°C to +8°C
- Analogue output: 0 V - 5 V
- RS-485 data interface
- Internal data logger
- External battery packs
- ROV and AUV installation packages
- Profiling and mooring frames
- External pump (SBE-5T or SBE-5M)
- Flow through version for underway (FerryBox) and lab applications

CONTROS HydroC™ CH₄

APPLICATIONS

The CONTROS HydroC™ CH₄ is trusted to deliver precise readings for diverse applications, including:

- Climate studies
- Methane hydrate studies
- Limnology
- Fresh water control
- Offshore leak detection

FEATURES

- New robust TOUGH membrane
- Improved gas cycle management for reliable long-term deployments
- Deep sea capability, water depths up to 6000 meters
- High accuracy and low detection limit of background concentration
- Large measuring range
- Optimal long-term stability
- Ideal methane selectivity
- Non-consuming CH₄ measurement
- User-friendly 'Plug & Play' principle; all cables, connectors and software included

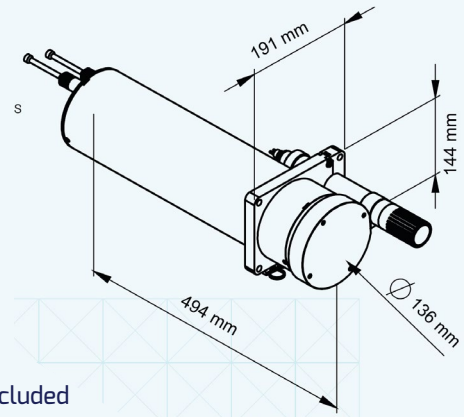

TECHNICAL SPECIFICATIONS

Detector	TDLAS -Tunable Diode Laser Absorption Spectroscopy	Temperature ranges¹	-2°C to +35°C
Measuring range	0- 40,000 µatm	Accuracy²	±2 µatm or ±3 %
Detection limit	< 1 µatm	Connector³	SUBCONN MCBH-M Titanium 8-pin
Weight		Supply voltage	12 V - 30 V
- in water	5.5 kg	Data format	ASCII and NMEA protocol
- in air	12.5kg	Power consumption⁴	Approx. 690 mA @ 12 V
Dimensions		- with SBE-5T ext. pump	additional 8 W
- without connector	136 x 494 mm	Data interface	RS-232C and RS485
- with connector	136 x 528 mm	Data format	ASCII
Operational depth	6,000 m		

1. Other ranges available 2. Whichever is greater 3. Other connectors on request 4. Approx. values for standard configuration at 20°C ambient temperature. Specifications subject to change without notice.

CONTACT -4H-JENA

Get in touch to find out how CONTROS HydroC™ CH₄ sensors can secure your ability to measure and report dependable methane data as part of your workflow.

-4H-JENA engineering GmbH
 Muehlenstr. 126
 07745 Jena
 Germany

Tel: +49 (0) 3641-2887-0
 Fax: +49 (0) 3641-2887-26
 E-Mail: info@4h-jena.de
 www.4h-jena.de



CONTACT YOUR LOCAL REPRESENTATIVE

The CONTROS HydroC™ CH₄ enables climate researchers to contribute towards meeting the United Nations Sustainable Development Goals.

